



WILDEN®

AIR OPERATED DOUBLE DIAPHRAGM PUMPS

A DOVER RESOURCES COMPANY

T2 Metal Pump

FLOW RATE TO 35 GPM (132.5 LPM)

MAXIMUM OPERATING PRESSURE = 125 PSI (8.6 BAR)

SPECIFICATIONS

WETTED HOUSINGS (Water Chambers and Manifolds)

MATERIAL	SHIP WT.
Aluminum	26 lbs. (12 kg.)
Hastelloy	40 lbs. (16 kg.)
316 S.S.	36 lbs. (16.6 kg.)

NON-WETTED HOUSINGS

DESCRIPTION	MATERIAL
Center Section	Polypropylene, Aluminum, or Nickel-plated Aluminum

Air Valve	Brass, Teflon®-coated Brass, or Nickel-plated Brass
-----------	---

MAXIMUM SUCTION LIFT CAPABILITY

DRY LIFT
17' (5.2 m)

The above figure represents the rubber-fitted pump capability.

MAXIMUM DIAMETER SOLIDS

1/8" (3.17 mm) Diameter

ELASTOMER OPTIONS

MATERIAL	TEMPERATURE LIMITS		
Polyurethane	+10 (-12.2)	to +150 (65.6)	F°
Neoprene	0 (-17.8)	to +200 (93.3)	F°
Buna-N®	+10 (-12.2)	to +180 (82.2)	F°
Norde®	-60 (-51.1)	to +280 (137.8)	F°
Viton®	-40 (-40.0)	to +350 (176.7)	F°
Saniflex™	-20 (-28.9)	to +220 (104.4)	F°
Teflon® PTFE	+40 (4.4)	to +300 (148.9)	F°
Wil-Flex™	-40 (-40.0)	to +225 (107.2)	F°

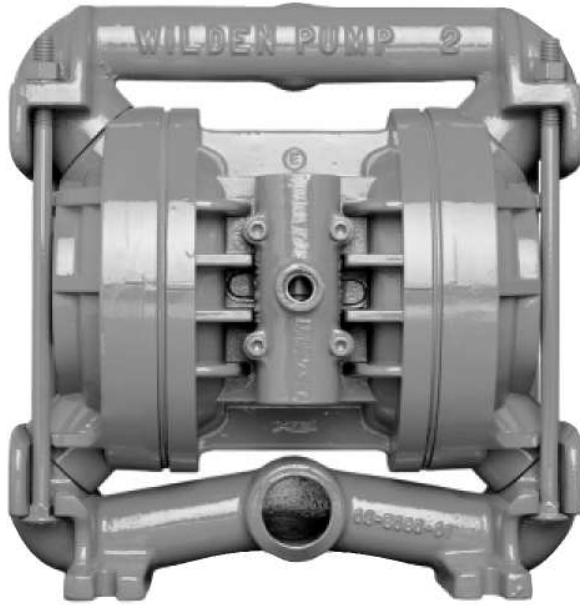

TURBOFLO
PROGRESSIVE PUMP TECHNOLOGY

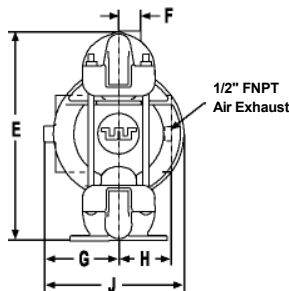
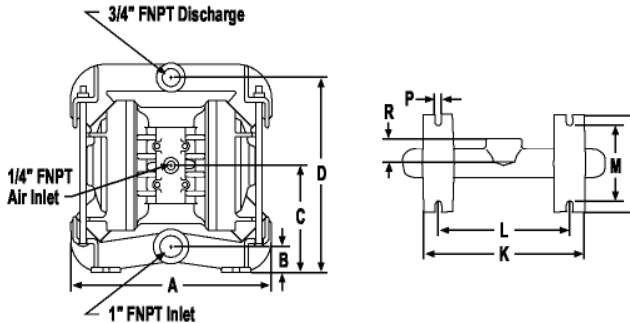

DIMENSIONS - T2 METAL

ITEM	STANDARD (inch)	METRIC (C)
A	10 17/32	267.5
B	1 7/16	36.5
C	5 7/16	138.0
D	10	254.0
E	11	279.4
F	1 1/8	28.6
G	3 3/4	95.3
H	3 1/32	77.0
J	7 1/4	184.2
K	8 1/4	209.6
L	6 3/4	171.5
M	4 3/16	106.4
N	5	127.0
P	5/16	7.9
R	1 1/4	31.8

BSP threads available for liquid inlet and discharge.
Refer to the EOM manual for TPE performance curve.

RUBBER-FITTED T2 METAL PUMP

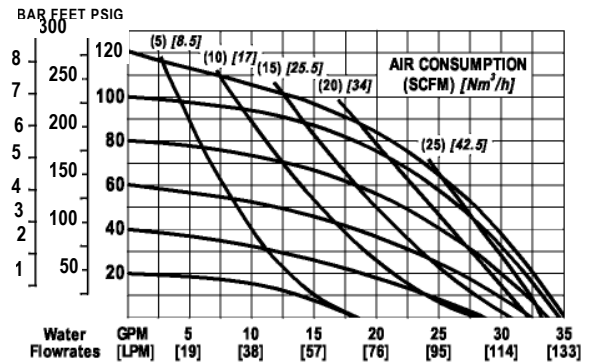

TEFLON®-FITTED T2 METAL PUMP

