

for drums **50/60 kg**

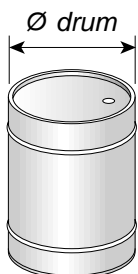

Art. 64064 for drums 50/60 kg with Ø from 370 to 420 mm

In addition to serving as a support for the pump, the **grease pump** trolley is structured to take various size containers. Equipped with 4 wheels, 2 fixed and 2 castors, it is very easy to handle.

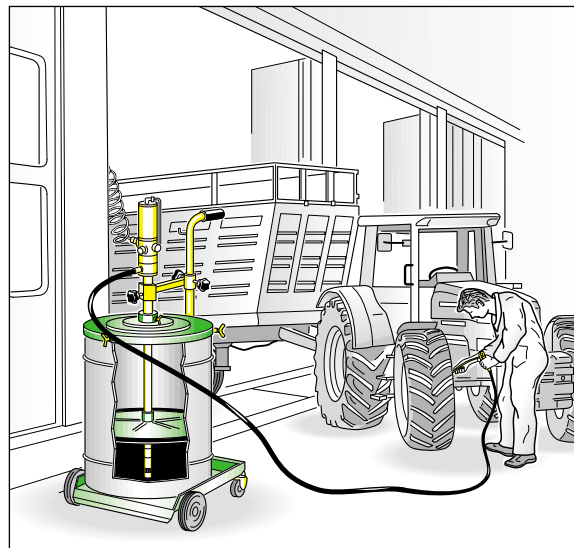

**The grease pump** : a practical, complete and handy combination for dispensing grease in small and medium size containers in any workplace (workshop, agriculture, industry, ...).

Art. 64064 **Grease pump** for drums 50/60 kg with **outside Ø from 370 to 420 mm** composed of:

- art. 62074 pump Ratio 50:1
- art. 80050 trolley
- art. 66892 nipples
- art. 91404 delivery hose 1/4" 4 m
- art. 66888 gun with straight swivel
- art. 65420 drum cover Ø 420 mm
- art. 66400 **follower plate Ø 400 mm**

N° 3 packing    m<sup>3</sup> 0,059    kg 22,4

Art. 64063 **Grease pump** for drums 50/60 kg with **outside Ø from 370 to 420 mm** same as 64064 but **without follower plate**

N° 3 packing    m<sup>3</sup> 0,059    kg 19,5

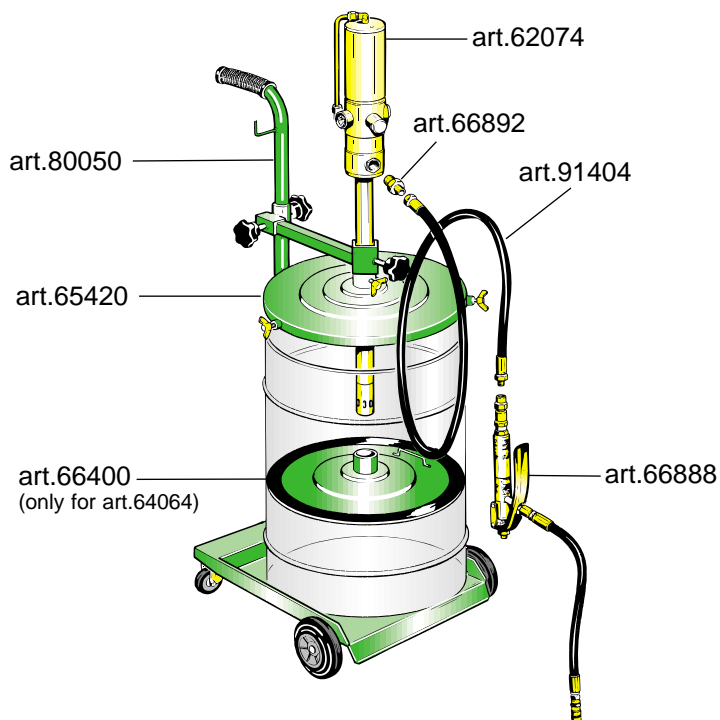

#### Overall dimensions

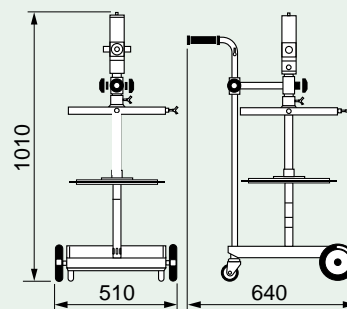

art. 64063 - 64064